



Bock Compressors F/F-NH₃

Assembly instructions

F2, F3

F4, F5

F14/1166, F14/1366

F16/1751, F16/2051

F2 NH₃, F3 NH₃

F4 NH₃, F5 NH₃

F14/1166 NH₃, F14/1366 NH₃

F16/1751 NH₃, F16/2051 NH₃

FX2, FX3

FX4, FX5

FX14/1166, FX14/1366

FX16/1751, FX16/2051

engineering for a better world



СтолицаХолода
ГЕА Refrigeration Technologies

создаем холод

сохраняем тепло

www.stolicaholoda.ru

About these instructions

Read these instructions before assembly and before using the compressor. This will avoid misunderstandings and prevent damage. Improper assembly and use of the compressor can lead to serious or fatal injury.

Observe the safety instructions contained in these instructions.

These instructions must be passed onto the end customer along with the unit in which the compressor is installed.

Manufacturer

GEA Bock GmbH
72636 Frickenhausen

Contact

GEA Bock GmbH
Benzstraße 7
72636 Frickenhausen
Germany

GB

Telephone +49 7022 9454 0
Fax +49 7022 9454-137
bock@gea.com
www.bock.de



Столица Холода
гипермаркет холодильного оборудования

09702-09.2013-DG6F

создаем холод





сохраняем тепло

www.stolichaholoda.ru

1	Safety	4
1.1	Identification of safety instructions	
1.2	Qualifications required of personnel	
1.3	General safety instructions	
1.4	Additional safety instructions NH ₃	
1.5	Intended use	
2	Product description	6
2.1	Short description	
2.2	Name plate	
2.3	Type code	
3	Areas of application F	9
3.1	Refrigerants F, F-NH ₃	
3.2	Oil charge	
3.3	Operating limits	
4	Areas of application F-NH₃	11
4.1	Oil charge NH ₃	
4.2	Operating limits NH ₃	
5	Compressor assembly	12
5.1	Setting up	
5.2	Maximum permissible inclination	
5.3	Pipe connections	
5.4	Pipes	
5.5	Laying suction and discharge lines	
5.6	Operating the shut-off valves	
5.7	Operating mode of the lockable service connections	
5.8	Drive	
5.9	Oil sump heating (standard by F4, F5, F14 and F16)	
6	Commissioning	18
6.1	Preparations for start-up	
6.2	Pressure resistance test	
6.3	Leak test	
6.4	Evacuation	
6.5	Refrigerant charge	
6.6	Shaft seal	
6.7	Shaft seal change	
6.8	Start-up	
6.9	Avoiding slugging	
7	Maintenance	21
7.1	Preparation	
7.2	Work to be carried out	
7.3	Spare parts recommendation	
7.4	Spare parts recommendation NH ₃	
7.5	Accessories	
7.6	Excerpt from the lubricant table	
7.7	Decommissioning	
8	Technical data F2-F16	23
9	Technical data F2 NH₃-F16 NH₃	24
10	Dimensions and connections F	25
11	Dimensions and connections F-NH₃	33
12	Declaration of installation	41
13	Service	42

1 | Safety

1.1 Identification of safety instructions:

	DANGER!	Indicates a dangerous situation which, if not avoided, will cause immediate fatal or serious injury.
	WARNING!	Indicates a dangerous situation which, if not avoided, may cause fatal or serious injury.
	CAUTION!	Indicates a dangerous situation which, if not avoided, may cause fairly severe or minor injury.
	ATTENTION!	Indicates a situation which, if not avoided, may cause property damage.
	INFO!	Important information or tips on simplifying work.

NH₃

INFO! This operating manual describes compressors that are suitable for both F-gases and for NH₃. Specific information and characteristics for using NH₃ are indicated at the corresponding location with the following symbols:

NH₃

1.2 Qualifications required of personnel

	WARNING!	<p>Inadequately qualified personnel poses the risk of accidents, the consequence being serious or fatal injury. Work on compressors is therefore reserved for personnel with the qualifications listed below:</p> <ul style="list-style-type: none">• For example, a refrigeration technician, refrigeration mechatronic engineer. As well as professions with comparable training, which enables personnel to assemble, install, maintain and repair refrigeration and air-conditioning systems. Personnel must be capable of assessing the work to be carried out and recognising any potential dangers.
---	-----------------	--

GB



СтолицаХолода
гипермаркет холодильного оборудования

09702-09.2013-DGbF

создаем холод

сохраняем тепло

www.stolicholoda.ru

1 | Safety

1.3 General safety instructions



DANGER!

- Refrigerating compressors are pressurised machines and as such call for heightened caution and care in handling. The maximum permissible overpressure must not be exceeded, even for testing purposes.



WARNING!

- Risk of burns! Depending on the operating conditions, surface temperatures of over 60°C on the discharge side or below 0°C on the suction side can be reached.

1.4 Additional safety instructions NH₃

NH₃

ATTENTION!

- High toxicity, intense odour (MAK 50 ppm)
- Explosive between 15 and 30 vol. % in the air. Due to the high ignition energy and temperature, the risk of explosion, however, is rated as low. So there are no special explosion protection measures are required.
- However, the national safety regulations, accident prevention regulations, technical regulations as well as specific regulations (EN 378 etc.) must be observed.
- NH₃ steam is lighter than air and therefore disperses upwards.
- All key directives are summarised in the area for the AiF research project 9404B "Safety of ammonia refrigeration systems".
- NH₃ corrodes copper materials and non-ferrous metals and is incompatible with a number of plastics.
- Proof of personnel's specific expertise for installation, commissioning, operation and service.

GB

1.5 Intended use

These assembly instructions describe the standard version of the compressor named in the title and NH₃ manufactured by Bock. The Bock refrigerating compressor are intended for installation in a machine (within the EU according to the EU Directives 2006/42/EC Machinery Directive, 97/23/EC Pressure Equipment Directive).

Commissioning is permissible only if the compressor has been installed in accordance with these assembly instructions and the entire system into which it is integrated has been inspected and approved in accordance with legal regulations.

Only the refrigerant specified in these instructions may be used.

Any other use of the compressor is prohibited!



WARNING! The compressor may not be used in potentially explosive environments!

2 | Product description

2.1 Short description

- Open type compressors for external drive (V-belt or coupling)
- with oil pump lubrication

Short description NH₃

Based on the F compressor series, a specially modified selection of compressors is available for use with the refrigerant R 717.

Important differences from the basic compressor F:

- Pistons with three-ring assembly
- Con-rod with additional oil supply oil to the small end
- Valve plate with optimised pressure unit
- Shut-off valve with steel connector for welded joints
- All connections are designed as compression joints for steel pipes
- F14 NH₃ and F16 NH₃ with increased oil volume due to the higher base plate
- Special oil filling for NH₃: Fuchs Reniso KC 68

GB

F2, F3

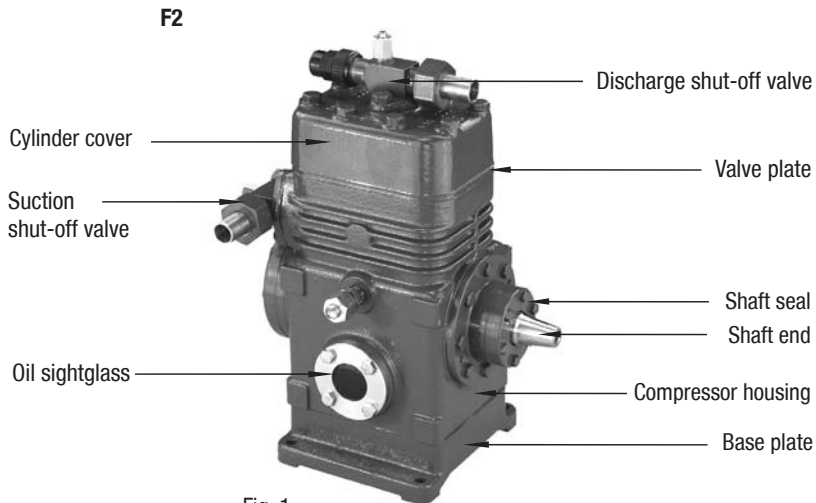

Fig. 1

Dimension and connection values can be found in Chapter 10

2 | Product description

F4, F5

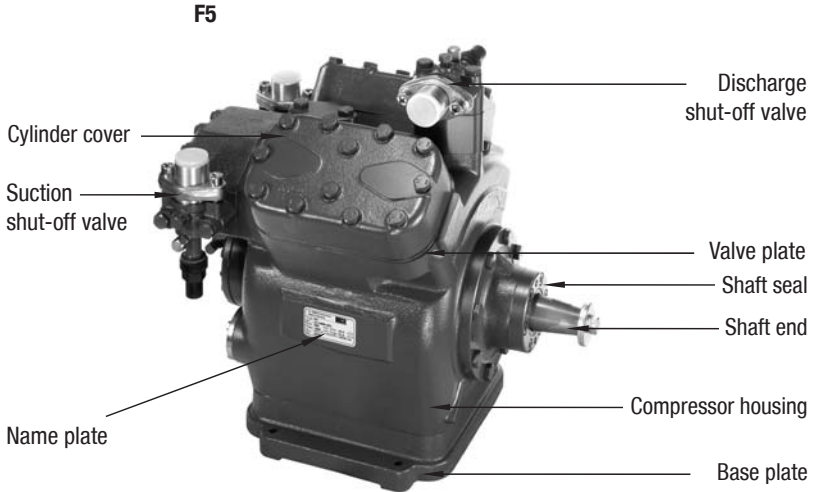

Fig. 2

GB

F14, F16

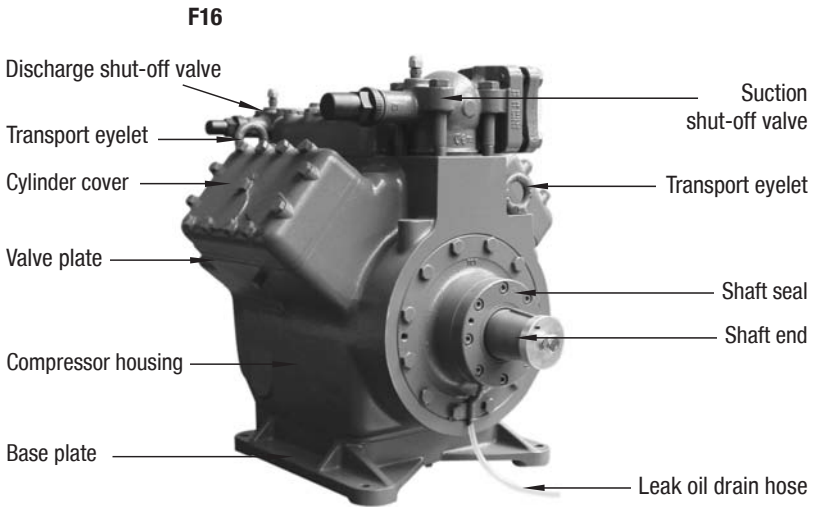

Fig. 3

09702-09.2013-DGbF

Dimension and connection values can be found in Chapter 10

2 | Product description

2.2 Name plate (example)

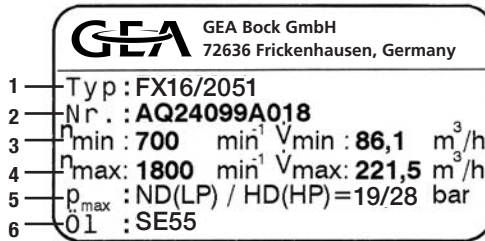

Fig. 4

- | | |
|---|--|
| 1 | Type designation |
| 2 | Machine number |
| 3 | Rotation speed minimum with a corresponding displacement |
| 4 | Rotation speed maximum with a corresponding displacement |
| 5 | ND(LP): Max. admissible operating pressure Suction side
HD(HP): Max. admissible operating pressure High-pressure side |
| 6 | Oil type charged at factory |

i Observe the limit of application diagrams!

GB

2.3 Type code (example)

FX14 / 1166 NH₃



¹⁾ X - Ester oil charge (HFC refrigerant R134a, R404A/R507, R407C)

²⁾ Indication only at F14, F16

3 | Areas of application F, F-NH₃

3.1 Refrigerants

- HFKW: R134a, R404A/R507, R407C
- (H)FCKW: R22
- NH₃: R717

3.2 Oil charge

- The compressors are filled with the following oil type at the factory:
 - for R134a, R404A/R507, R407C FUCHS Reniso Triton SE 55
 - for R22 FUCHS Reniso SP 46

Compressors with ester oil charge (FUCHS Reniso Triton SE 55) are marked with an X in the type designation (e.g. FX16/2051).



INFO! For refilling, we recommend the above oil types.
Alternatives: see lubricants table, Chapter 7.6



ATTENTION! The oil level must be in the visible part of the sight glass; damage to the compressor is possible if overfilled or underfilled!

max. oil level
min. oil level

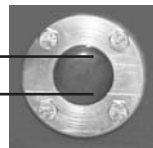

Fig. 5

GB

3.3 Operating limits



ATTENTION! Compressor operation is possible within the operating limits shown in the diagrams. Please note the significance of the shaded areas. Thresholds should not be selected as design or continuous operating points.

- Max. permissible discharge end temperature: 140°C
- Max. permissible switching frequency: 12x /h
- A minimum running time of 3 min. steady-state condition (continuous operation) must be achieved.
- Avoid continuous operation near the threshold.
- For operation with supplementary cooling:
 - Use only oils with high thermal stability.
- For operation with capacity regulator:
 - The suction gas superheat temperature may need to be reduced or set individually when operating near to the threshold.
- When operating in the vacuum range, there is a danger of air entering on the suction side. This can cause chemical reactions, a pressure rise in the condenser and an elevated compressed-gas temperature. Prevent the ingress of air at all costs!



3|Areas of application F

3.3 Operating limits

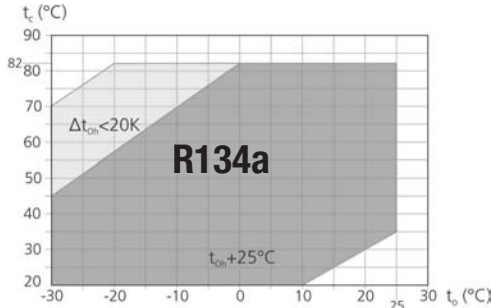

Fig. 6

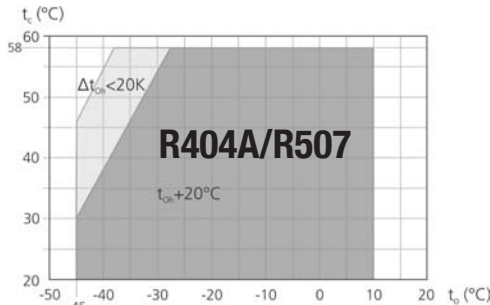

Fig. 7

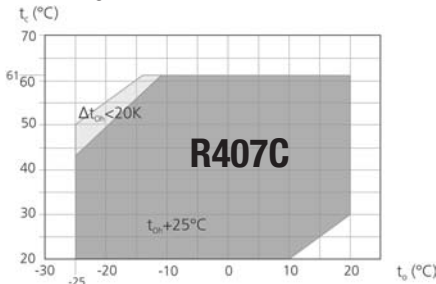

Fig. 8

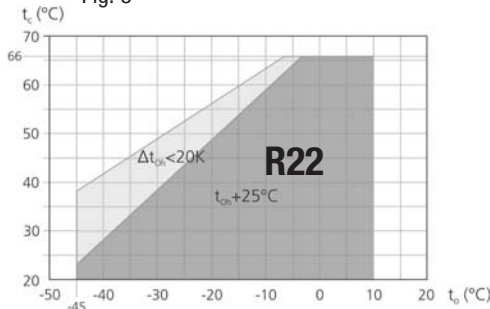

Fig. 9

- Unlimited application range
- Reduced suction gas temperature

- t_o Evaporating temperature (°C)
- t_c Condensing temperature (°C)
- Δt_{oh} Suction gas superheat (K)
- t_{oh} Suction gas temperature (°C)

Permissible rotation speeds:

F2, F3: 960 - 1800 rpm

F4, F5: 500 - 1800 rpm

F14, F16: 700 - 1800 rpm

**Maximum admissible
operating pressure (g)
High pressure side (LP/HP)¹⁾:
19/28 bar**

¹⁾ LP = Low pressure

HP = High pressure

**Design for other
areas on request**

GB

09702-09.2013-DGbF

Столица Холода
гипермаркет холодильного оборудования

создаем холод сохраняем тепло

www.stolicaholoda.ru

4| Areas of application F-NH₃



NH₃

4.1 Oil charge NH₃

- The compressors are filled with the following oil type at the factory:
- for R717: Fuchs Reniso KC 68

4.2 Operating limits NH₃

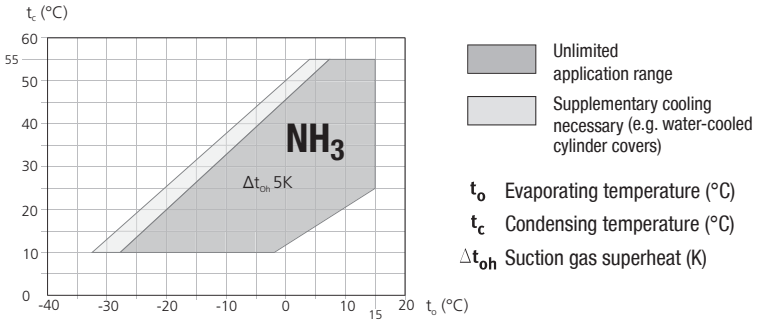

Fig. 10

Permissible rotation speeds:

F2 NH₃, F3 NH₃: 960 - 1500 rpm

F4 NH₃, F5 NH₃: 500 - 1500 rpm

F14 NH₃, F16 NH₃: 700 - 1500 rpm

Max. permissible operating pressure (LP/HP)¹⁾: 19/25 bar

¹⁾ LP = Low pressure
HP = High pressure

Design for other areas on request

GB



5| Compressor assembly



INFO!

New compressors are factory-filled with inert gas (3 bar nitrogen). Leave this service charge in the compressor for as long as possible and prevent the ingress of air. Check the compressor for transport damage before starting any work.

5.1 Setting up



WARNING! Move compressors only with hoists that have adequate load-bearing capacity.

- Transport and suspension unit on the eyebolt (Fig. 12, F14 to F16) or direct on the discharge line valve (Fig. 11, F2 to F5).

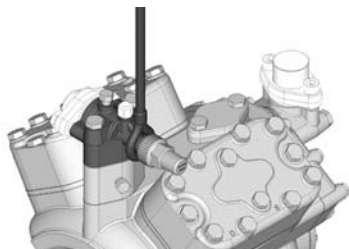

Fig. 11

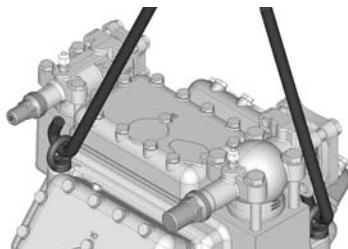

Fig. 12

- Fittings (e.g. pipe holders, additional units etc.) on the compressor are permissible only following consultation with Bock.
- Setup on an even surface or frame with sufficient load-bearing capacity. Use all 4 fastening points.
- Correct setup of the compressor and mounting of the belt drive are decisive for running comfort, operating safety and the service life of the compressor.

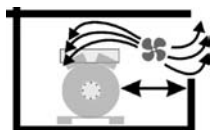

Fig. 13

- Provide adequate clearance for maintenance work.
- Provide adequate ventilation for the drive motor.



Fig. 14

- Do not use in a dusty, damp atmosphere or a combustible environment.

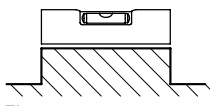

Fig. 15

- Set up on an even surface or frame with sufficient load-bearing capacity.
- Compressors and drive motors are basically rigid and should be mounted together on a base frame.

5| Compressor assembly

5.2 Maximum permissible inclination



ATTENTION! Poor lubrication can damage the compressor.
Respect the stated values.

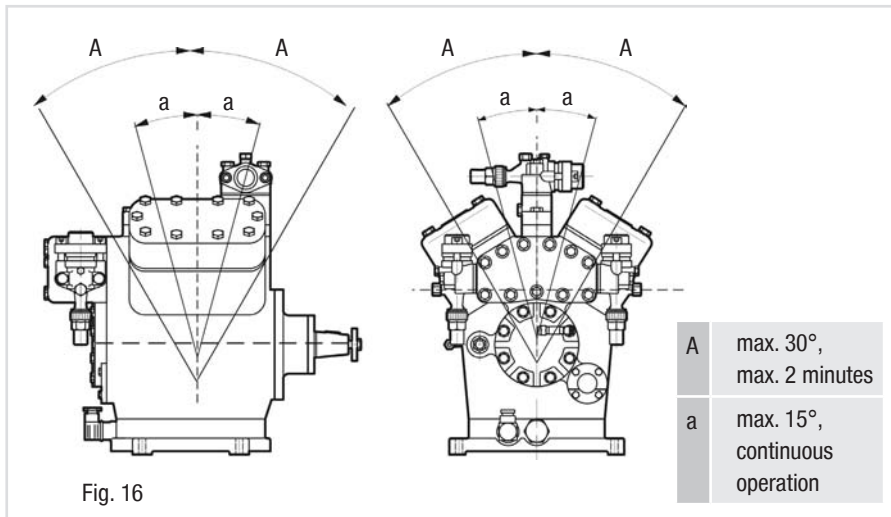

Fig. 16

GB

5.3 Pipe connections



ATTENTION! Overheating can damage the valve.
Remove the pipe supports from the valve for soldering.
Only solder using inert gas to inhibit oxidation products (scale).

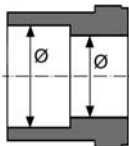

Fig. 17: Stepped
internal diameters

- The **pipe connections** have stepped internal diameters so that pipes with standard millimetre and inch dimensions can be used.
- The connection diameters of the shut-off valves are designed for maximum compressor output. **The required pipe cross-section must be matched to the capacity. The same applies for non-return valves.**
- The required tightening torque for the flange connection is 60 Nm.

5.4 Pipes

- Pipes and system components must be clean and dry inside and free of scale, swarf and layers of rust and phosphate. Only use air-tight parts.
- Lay pipes correctly. Suitable vibration compensators must be provided to prevent pipes being cracked and broken by severe vibrations.
- Ensure a proper oil return.
- Keep pressure losses to an absolute minimum.



СтолицаХолода
гипермаркет холодильного оборудования

создаем холод

сохраняем тепло 13

www.stolicholoda.ru

5 | Compressor assembly

5.5 Laying suction and discharge lines



INFO! Proper layout of the suction and discharge lines directly after the compressor is integral to the system's smooth running and vibration behaviour.



ATTENTION! Improperly installed pipes can cause cracks and tears, the result being a loss of refrigerant.

A rule of thumb:

Always lay the first pipe section starting from the shut-off valve **downwards** and **parallel to the drive shaft**.

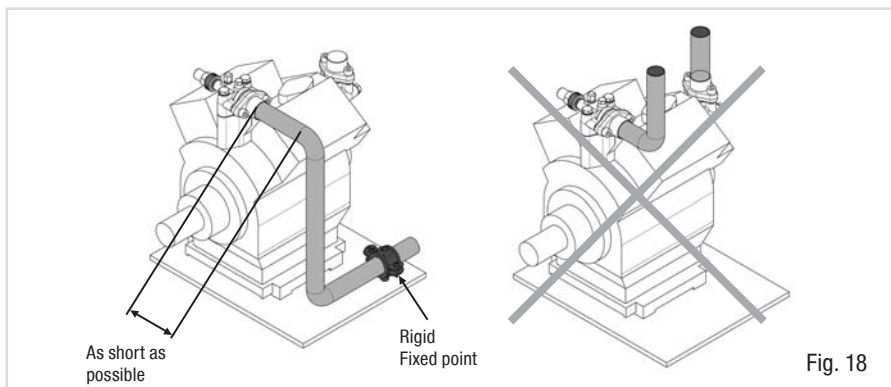

GB

5.6 Operating the shut-off valves

- Before opening or closing the shut-off valve, release the valve spindle seal by approx. ¼ of a turn counter-clockwise.
- After activating the shut-off valve, re-tighten the adjustable valve spindle seal clockwise.

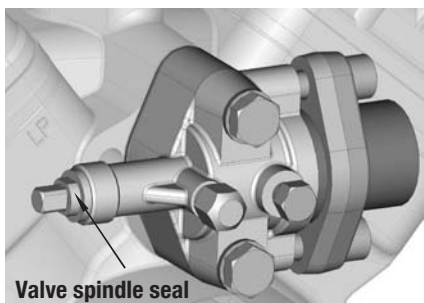

Fig. 19

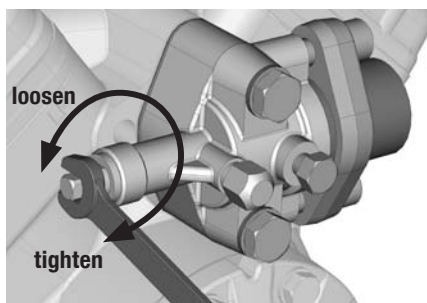

Fig. 20

5| Compressor assembly

5.7 Operating mode of the lockable service connections

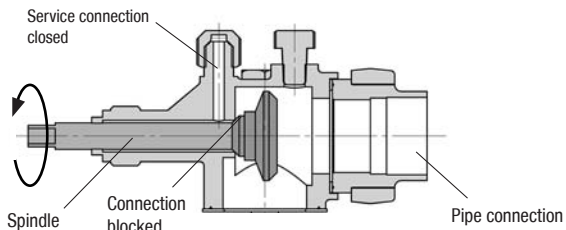

Fig. 21

Opening the shut-off valve:

Spindle: turn to the left (counter-clockwise) as far as it will go.

—> The shut-off valve is then fully open and the service connection is closed.

The connection which is not lockable is provided for safety devices.

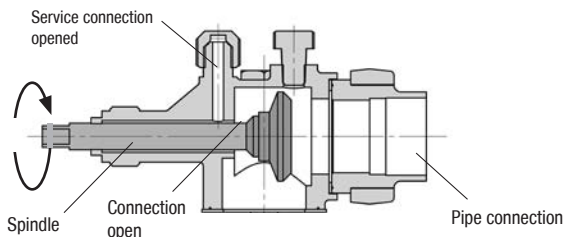

GB

Fig. 22

Opening the service connection

Spindle: $\frac{1}{2}$ - 1 rotation to the right (clockwise).

—> The service connection is then open and the shut-off valve is also open.

The connection which is not lockable is provided for safety devices.

5| Compressor assembly

5.8 Drive



ATTENTION! Faulty alignment results in premature failure of the coupling and bearing damage!



CAUTION! Mount suitable safeguards when driving the compressor by means of V-belts or shaft couplings!

The compressors of the F series can be driven by V-belts or directly by shaft couplings.

V-belt:

- Proper assembly of belt drive:
 - The pulleys of compressor and drive motor must be firmly mounted and in line.
 - Only use V-belts with calibrated lengths.
 - Select axis spacing, V-belt length and belt pre-tension according to the instructions issued by the V-belt manufacturer. Avoid belt fluttering.
 - Check belt pre-tension after running-in time.

Direct drive with shaft coupling:

- Direct drive with shaft couplings demands highly precise aligning of compressor shaft and motor shaft.
- Use the Bock shaft couplings „WK“ and observe the enclosed assembly instructions.

GB



СтолицаХолода
гипермаркет холодильного оборудования

09702-09.2013-DGbF

создаем холод

сохраняем тепло

www.stolicaholoda.ru

5| Compressor assembly

5.9 Oil sump heating

When the compressor is at a standstill, refrigerant diffuses into the lubrication oil of the compressor housing, depending on pressure and ambient temperature. This reduces the lubrication capacity of the oil. When the compressor starts up, the refrigerant contained in the oil evaporates out through the reduction in pressure. The consequences can be lack of lubrication, foaming and migration of the oil, which can eventually lead to compressor damage.

To prevent this, the oil can be heated via an oil sump heater.

Operation: Oil sump heater ON at standstill of the compressor.

Oil sump heater OFF during operation of the compressor

Connection: Oil sump heater must be connected via an auxiliary contact (or parallel wired auxiliary contact) of the motor contactor to a separate electric circuit.

Oil sump heater: 230 V – 1 – 50/60Hz, IP65

Type	F2	F3	F4	F5	F14	F16
Electrical power (Watt)	40	60	80	80	140	140

NH₃

INFO! Same electrical performance even on NH₃ compressors



WARNING! The oil sump heater must not be connected to the electrical circuit of the safety control chain !

GB



6| Commissioning

6.1 Preparations for start-up



INFO!

To protect the compressor against inadmissible operating conditions, high pressure and low pressure pressostats are mandatory on the installation side.

The compressor has undergone trials in the factory and all functions have been tested. There are therefore no special running-in instructions.

Check the compressor for transport damage!

6.2 Pressure strength test



DANGER!

Bursting! The compressor must only be pressurised using nitrogen (N₂). Never pressurise with oxygen or other gases! The maximum permissible overpressure of the compressor must not be exceeded at any time during the testing process (see name plate data)! Do not mix any refrigerant with the nitrogen as this could cause the ignition limit to shift into the critical range.

The compressor has been factory-tested for pressure resistance. The following must be observed if the entire plant is subjected to an additional pressure strength test:

- Test the refrigeration circuit according to EN 378-2 or a corresponding safety standard.

6.3 Leak test



DANGER!

Bursting!

Do not mix any refrigerant with the nitrogen (N₂) as this could cause the ignition limit to shift into the critical range.

- Carry out the leak test of the refrigerating system in accordance with EN 378-2 or a corresponding safety standard **without including the compressor.**

6.4 Evacuation

- First evacuate the **system** and then include **the compressor in the evacuation process.**
- Relieve the compressor pressure.
- Open the suction and discharge line valves.
- Evacuate the suction and discharge pressure sides using the vacuum pump.
- At the end of the evacuation process, the vacuum should be < 1.5 mbar when the pump is switched off.
- Repeat the process as often as is required.

GB



6| Commissioning

6.5 Refrigerant charge



CAUTION! Wear personal protective clothing such as goggles and protective gloves!

- Make sure that the suction and discharge line valves are open.
- With the compressor switched off, add the liquid refrigerant directly to the condenser or receiver, breaking the vacuum.
- If the refrigerant needs topping up after starting the compressor, it can be topped up in vapour form on the suction side, or, taking suitable precautions, also in liquid form at the inlet to the evaporator.



ATTENTION!

- **Avoid overfilling the system with refrigerant!**
- **To avoid shifts in concentration, zeotropic refrigerant blends must always only be filled into the refrigerating plant in liquid form.**
- **Do not pour liquid coolant through the suction line valve on the compressor.**
- **It is not permissible to mix additives with the oil and refrigerant.**

GB

6.6 Shaft seal



ATTENTION! Failure to observe the following instructions can cause loss of refrigerant and damage to the shaft seal!



INFO!

- **The shaft seal seals and lubricates with oil. An oil leakage of 0.05 ml per operating hour is therefore normal. This applies particularly during the run-in phase (200 - 300 h).**
- **The compressor types F14 and F16 are equipped with a leak oil drain hose (see chapter 10 and 11). The leak oil is continually discharged through the leak oil drain hose. To collect the leak oil, a receptacle is to be provided by the plant operator. Dispose of the leak oil in accordance with the valid national regulations.**

The compressor shaft is sealed to outside using a shaft seal. The sealing element rotates with the shaft.

The following is especially important to ensuring fault-free operation:

- The complete refrigerant circuit must be correctly executed and clean inside.
- Heavy shocks and vibrations to the shaft as well as continuous cyclic operation are to be avoided.
- The sealing surfaces can stick together during prolonged downtimes (e.g. winter). Therefore, run the system every 4 weeks for 10 minutes.



СтолицаХолода
гипермаркет холодильного оборудования

создаем холод

сохраняем тепло 19

www.stolicholoda.ru

6| Commissioning

6.7 Shaft seal change

As changing the shaft seal involves opening the refrigerant circuit, this is recommended only if the seal is losing refrigerant. Replacing the shaft seal is described in the spare part kit concerned.

6.8 Start-up



WARNING! Ensure that both shut-off valves are open before starting the compressor!

- Check that the safety and protection devices (pressure switch, motor protection, electrical contact protection measures, etc.) are all functioning properly.
- Switch on the compressor and allow to run for a minimum of 10 min.
- Check the oil level **by**: The oil must be visible in the sightglass.



ATTENTION! If larger quantities of oil have to be topped up, there is a risk of oil hammer effects. If this is the case check the oil return!

GB

6.9 Avoiding slugging



ATTENTION! Slugging can damage the compressor and cause coolant to leak.

To prevent slugging:

- The complete refrigeration system must be properly designed.
- All components must be compatibly rated with each other with regard to output (particularly the evaporator and expansion valves).
- Suction gas superheat at the compressor input **should be min. 7 - 10 K.** (check the setting of the expansion valve).
- The system must reach a state of equilibrium.
- Particularly in critical systems (e.g. several evaporator points), measures are recommended such as replacement of liquid traps, solenoid valve in the liquid line, etc.

There should be no movement of coolant whatsoever while the compressor is at a standstill.



7 | Maintenance

7.1 Preparation



- WARNING!** Before starting any work on the compressor:
- Switch off the compressor and secure it to prevent a restart.
 - Relieve compressor of system pressure.
 - Prevent air from infiltrating the system!
- After maintenance has been performed:
- Connect safety switch.
 - Evacuate compressor.
 - Release switch lock.

7.2 Work to be carried out

To guarantee optimum operating safety and service life of the compressor, **we recommend** performing service and checking work at regular intervals of time:

- **Oil change:**
 - In series plants produced in the factory not mandatory.
 - In field installations or operating in the application limit range, first oil change after approx. 100 - 200 operating hours, then approx. every 3 years or 10,000 - 12,000 operating hours.
 - for NH₃ plants: oil change every year or every 5.000 operating hours.
Dispose of old oil according to the regulations, observe national regulations.
- **Annual checks:** Oil level, tightness, running noise, pressures, temperatures, function of auxiliary devices such as a oil sump heater, pressure switch. Comply with the national regulations!

GB

7.3 Spare parts recommendation

Type	F2	F3	F4	F5	F14/1166 F14/1366	F16/1751 F16/2051
Designation	Ref. No.					
Set gaskets	08069	08070	08071	08072	08492	08493
Shaft seal	08001	08001	08008	08008	08444	08012
Valve plate set	08314	08198	08198	08436	08498	08498
Oil pump	08043	08043	08044	08044	08795	08795
Oil sump heater	08423	08424	08425	08425	08426	08426

Only use original Bock spare parts!

7 | Maintenance

7.4 Spare parts recommendation NH₃

NH ₃	Type	F2 NH ₃	F3 NH ₃	F4 NH ₃	F5 NH ₃	F14/1166 NH ₃ F14/1366 NH ₃	F16/1751 NH ₃ F16/2051 NH ₃
	Designation	Ref. No.					
	Set gaskets	08069	08070	08071	08072	08492	08493
	Shaft seal	08001	08001	08008	08008	08444	08012
	Valve plate set NH ₃	08841	08842	08842	08843	08844	08844
	Oil pump	08043	08043	08044	08044	08799	08799
	Oil sump heater	08423	08424	08425	08425	08426	08426

Only use original Bock spare parts!

7.5 Accessories

Accessories available can be found in the F-Catalogue (Bock Ref.-No. 96023) or on the Internet at www.bock.de.

7.6 Excerpt from the lubricant table

The oil grade filled as standard in the factory is noted on the **name plate**. **This oil grade should be used preferably**. Alternatives to this are listed in the following excerpt from our lubricant table.

Refrigerant	Bock series oil grades	Recommended alternatives
HFkW (e.g. R134a, R404A/R507, R407C)	Fuchs Reniso Triton SE 55	FUCHS Reniso Triton SEZ 32 ICI Emkarate RL 32 H, S MOBIL Arctic EAL 32 SHELL Clavus R 32
HFCKW (e.g. R22)	Fuchs Reniso SP 46	FUCHS Reniso, z.B. KM, HP, SP 32 SHELL Clavus SD 22-12 TEXACO Capella WF 46
NH₃	Fuchs Reniso KC 68 for flooded operation Fuchs Reniso Synth 68 for applications using a plate heat exchanger	-

Information on further suitable oils on request.

7.7 Decommissioning

Close the shut-off valves on the compressor. Drain the refrigerant (it must not be discharged into the environment) and dispose of it according to the regulations. When the compressor is depressurised, undo the fastening screws of the shut-off valves. Remove the compressor using an appropriate hoist. Dispose of the oil inside in accordance with the applicable national regulations.

8| Technical data F2 - F16

Type	No. of cylinders	Displacement (1450/1740 rpm)	Weight ²⁾	Connections ¹⁾		Oil charge	Rotation speed range
				Discharge line DV	Suction line SV		
F2	2	m ³ /h	kg	mm inch	mm inch	ltr.	rpm
		10,50 / 12,60	18	16 5/8	16 5/8	0,8	960-1800
F3		20,30 / 24,30	28	22 7/8	28 1 1/8	1,5	
F4	4	40,50 / 48,60	51	28 1 1/8	35 1 3/8	2,6	500-1800
F5		73,70 / 88,40	85	35 1 3/8	2 x 35 1 3/8	3,8	
F14/1166	4	101,40 / 121,70	149	42 1 5/8	54 2 1/8	3,8	700-1800
F14/1366		119,00 / 142,80					
F16/1751	6	152,20 / 182,60	175	42 1 5/8	54 2 1/8	5,0	700-1800
F16/2051		178,40 / 214,10					

¹⁾ for soldering joint
²⁾ in standard design

9| Technical data F2-NH₃ - F16-NH₃

GB

Type	No. of cylinders	Displacement (1450 rpm) m ³ /h	Weight ²⁾ kg	Connections ¹⁾		Oil charge ltr.	Rotation speed range rpm
				Discharge line DV mm	Suction line SV mm		
F2 NH ₃	2	10,50	18	18	0,8	960-1500	
F3 NH ₃		20,30	28	25	1,5		
F4 NH ₃	4	40,50	51	30	2,6	500-1500	
F5 NH ₃		73,70	85	38	3,8		
F14/1166 NH ₃ F14/1366 NH ₃	4	101,50 118,90	158	49	6,3	700-1500	
F16/1751 NH ₃ F16/2051 NH ₃	6	152,20 178,40	183	49	7,5	700-1500	

¹⁾ for soldering joint

²⁾ in standard design

Столица Холода
г.п.о. маркет холодильного оборудования

создаем холод сохраняем тепло

www.stolicaholoda.ru

09702-09.2013-DG6F

10| Dimensions and connections F

Compressor type F2

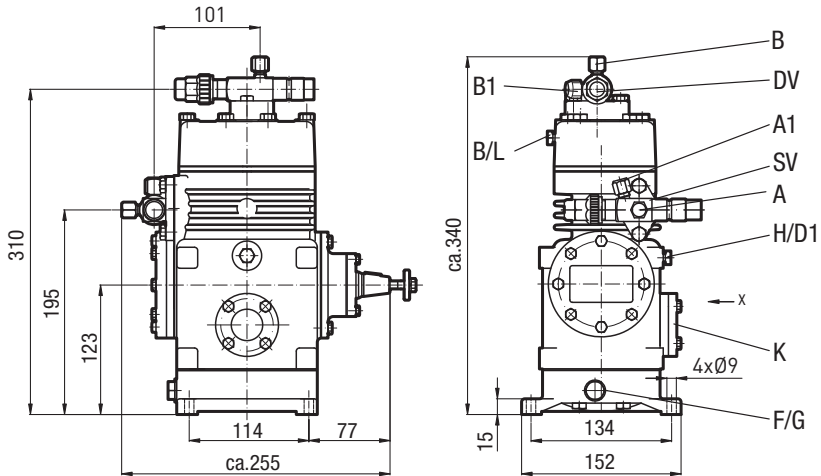

Fig. 23
Dimensions in mm

GB

Shaft end F2

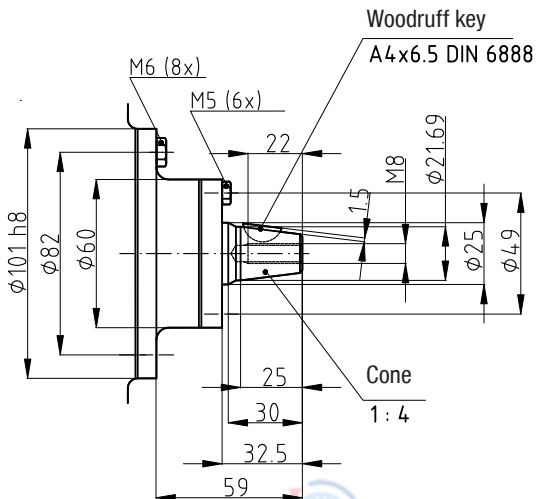

Fig. 24
Dimensions in mm
Dimensions for view X see page 32

09702-09.2013-DGbF



Stolica Холода
производства

создаем холод

сохраняем тепло

www.stolicaholoda.ru

10| Dimensions and connections F

Compressor type F3

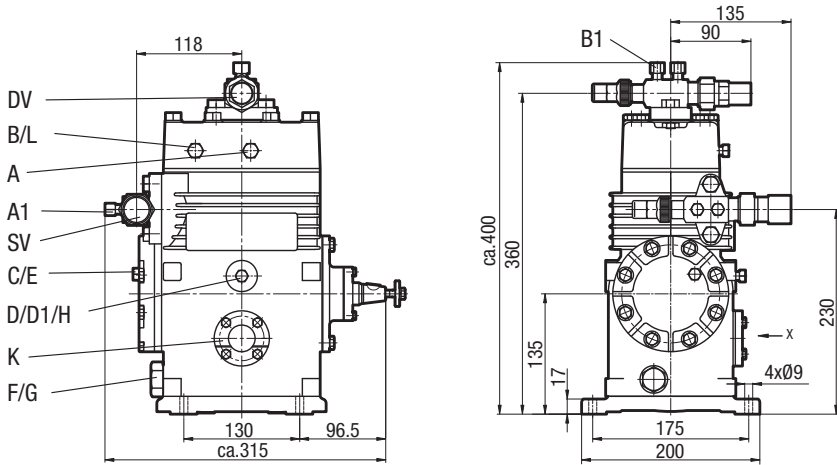

Fig. 25
Dimensions in mm

Shaft end F3

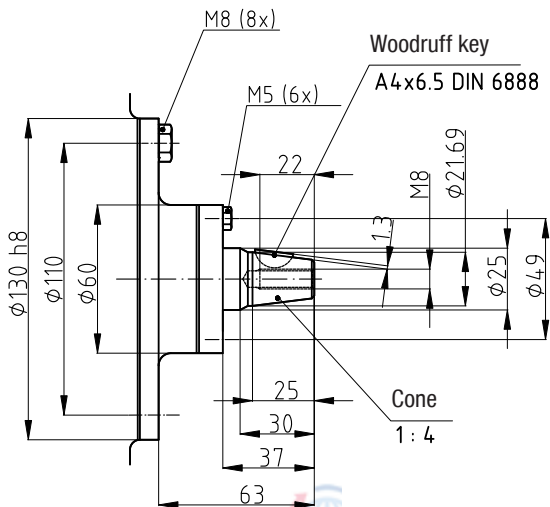

Fig. 26
Dimensions in mm
Dimensions for view X see page 32

GB

10| Dimensions and connections F

Compressor type F4

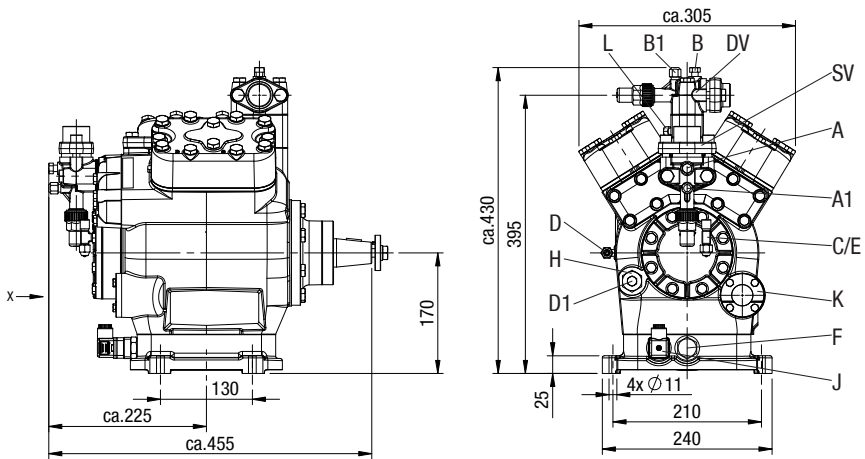

Fig. 27
Dimensions in mm

GB

Shaft end F4

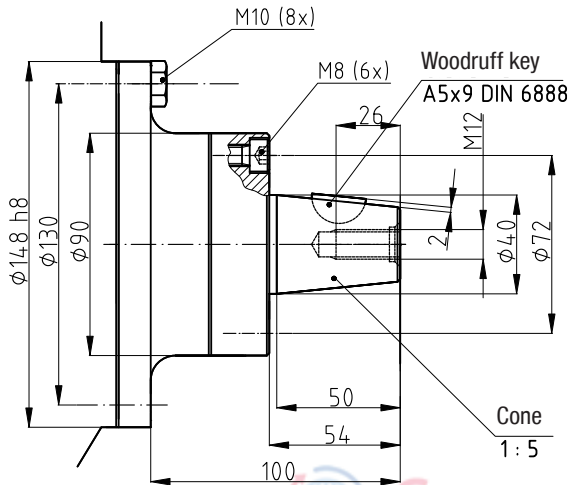

Fig. 28
Dimensions in mm
Dimensions for view X see page 32

09702-09.2013-DGbF

10| Dimensions and connections F

Compressor type F5

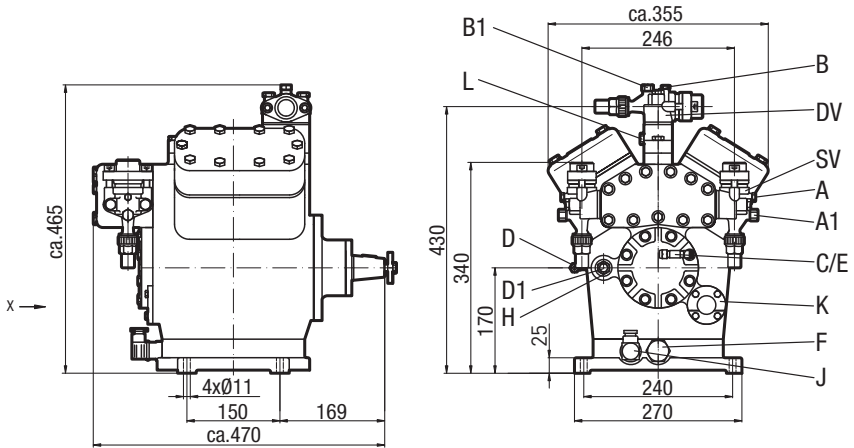

Fig. 29
Dimensions in mm

Shaft end F5

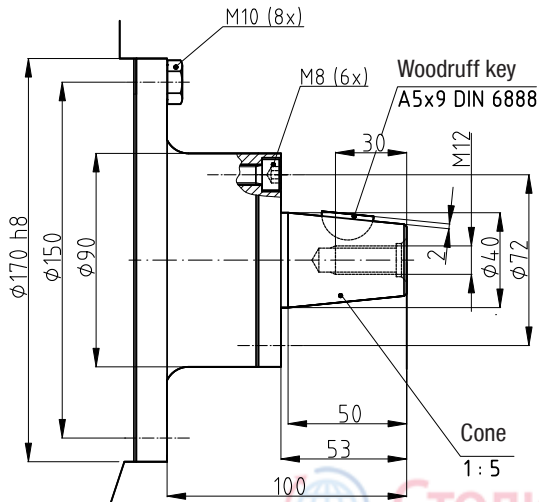

Fig. 30
Dimensions in mm
Dimensions for view X see page 32

GB

10| Dimensions and connections F

Compressor type F14

F14/1166

F14/1366

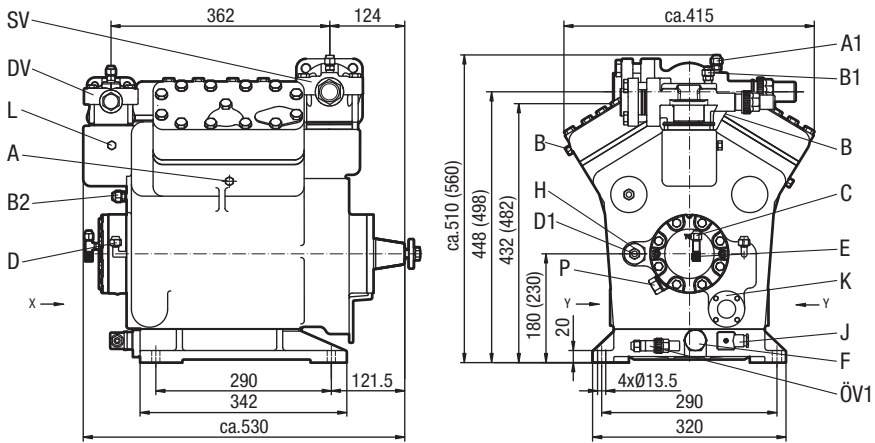

Fig. 31

Dimensions in mm

Dimensions in () = with elevated base plate

GB

Shaft end F14

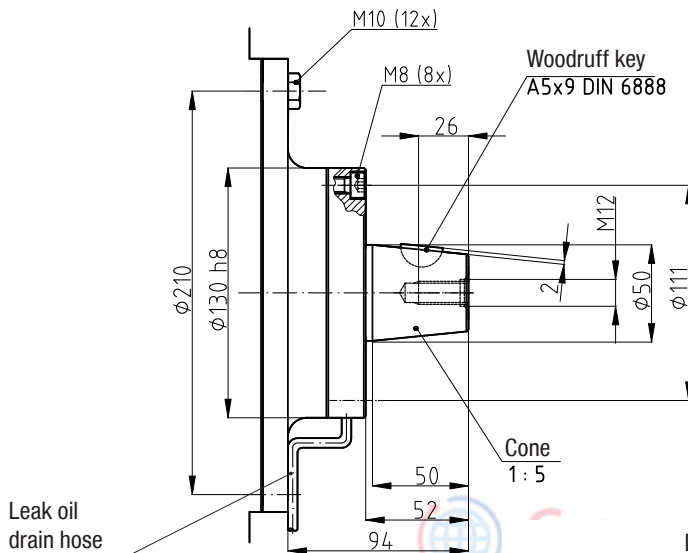

Fig. 32

Dimensions in mm

Dimensions for view X, Y see page 32

10| Dimensions and connections F

Compressor type F16

F16/1751

F16/2051

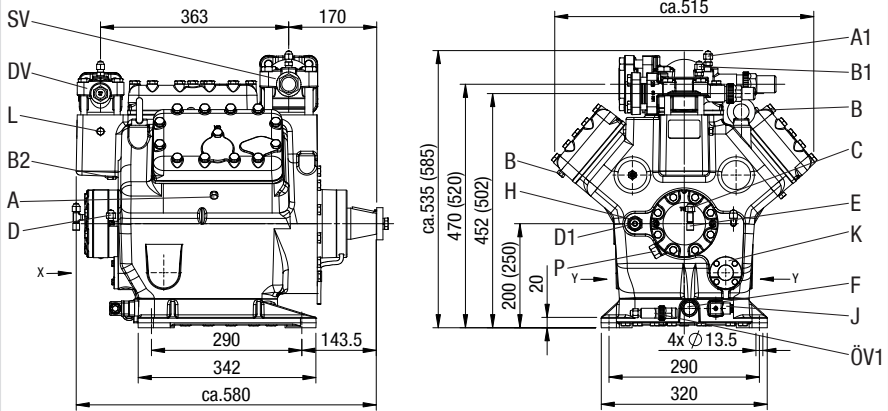

Fig. 33

Dimensions in mm

Dimensions in () = with elevated base plate

GB

Shaft end F16

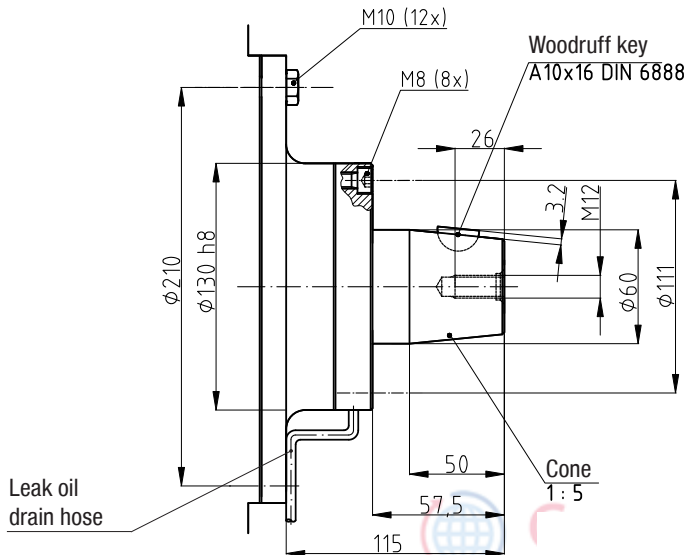

Fig. 34

Dimensions in mm

Dimensions for view X, Y see page 32

10 | Dimensions and connections F

	Connections	F2	F3	F4	F5	F14	F16
SV	Suction line						
DV	Discharge line						
		see technical data, Chapter 8					
A	Connection suction side, not lockable	7/16" UNF	1/8" NPTF	1/8" NPTF	1/8" NPTF	1/8" NPTF	1/8" NPTF
A1	Connection suction side, lockable	7/16" UNF	7/16" UNF	7/16" UNF	7/16" UNF	7/16" UNF	7/16" UNF
B	Connection discharge side, not lockable	1/8" NPTF	1/8" NPTF	1/8" NPTF	1/8" NPTF	1/8" NPTF	1/8" NPTF
B1	Connection discharge side, lockable	7/16" UNF	7/16" UNF	7/16" UNF	7/16" UNF	7/16" UNF	7/16" UNF
B2	Connection discharge side, not lockable	-	-	-	-	7/16" UNF	7/16" UNF
C	Connection oil pressure safety switch OIL	-	1/8" NPTF	7/16" UNF	7/16" UNF	7/16" UNF	7/16" UNF
D	Connection oil pressure safety switch LP	-	1/8" NPTF	7/16" UNF	7/16" UNF	7/16" UNF	7/16" UNF
D1	Connection oil return from oil separator	1/8" NPTF	1/8" NPTF	1/8" NPTF	1/8" NPTF	5/8" UNF	5/8" UNF
E	Connection oil pressure gauge	-	1/8" NPTF	7/16" UNF	7/16" UNF	7/16" UNF	7/16" UNF
F	Oil drain plug	R 3/8"	M22 x 1,5	M22 x 1,5	M22 x 1,5	M26 x 1,5	M26 x 1,5
H	Oil charge plug	1/8" NPTF	1/8" NPTF	M22 x 1,5	M22 x 1,5	M22 x 1,5	M22 x 1,5
J	Oil sump heater	R 3/8" 1)	M22 x 1,5 1)	M22 x 1,5	M22 x 1,5	M22 x 1,5	M22 x 1,5
K	Sight glass	4 hole M6	4 hole M6	4 hole M6	4 hole M6	4 hole M6 3)	4 hole M6 3)
L	Connection thermal protection thermostat	1/8" NPTF	1/8" NPTF	1/8" NPTF	1/8" NPTF	1/8" NPTF	1/8" NPTF
P	Connection for differential oil pressure sensor	-	-	-	-	M20 x 1,5	M20 x 1,5
OV	Oil service valve	-	-	-	-	7/16" UNF	7/16" UNF

1) Oil sump heating optional

2) No connection available as standard. Available on request (Connection R 3/8")

3) Second sight glass can be attached, Positioning view Y (optional, available only as original equipment)

10| Dimensions and connections

10.1 View X, Y

- Oil sight glass
- Connection facility for parallel operation

Position view X:

F2, F3, F4, F5, F14, F16
4 hole oil sight glass

Position view Y:

F14, F16
Second oil sight glass can be attached as an option (available as original equipment only)

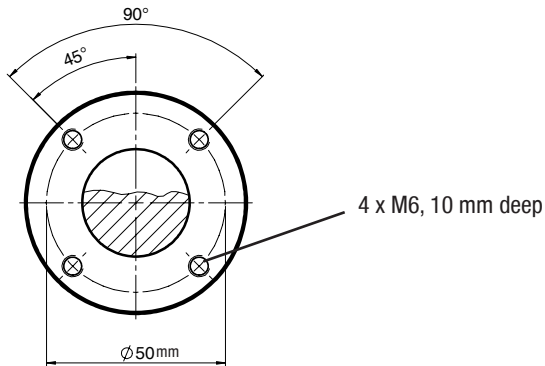

Connection facilities

Operation with oil level regulator

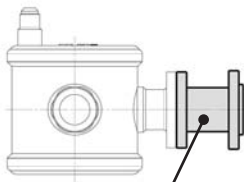

Art.Nr. 80462

BOCK adapter for oil level regulator, fits the makes ESK, AC+R, CARLY.
3 hole fastener on the side of the oil level regulator
4 hole fastener on the side of the compressor

Operation with common oil-gas balance pipe

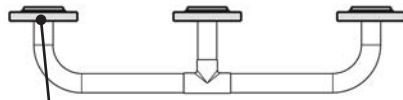

example: 3 compressors in parallel

Art.Nr. 80463

BOCK adapter for oil-gas regulator, single design,
4 hole steel connector for Pipe \varnothing 35 mm, fits all sight glass positions.
1 item per compressor required.

GB

11 | Dimensions and connections F-NH₃

Compressor type F2 NH₃

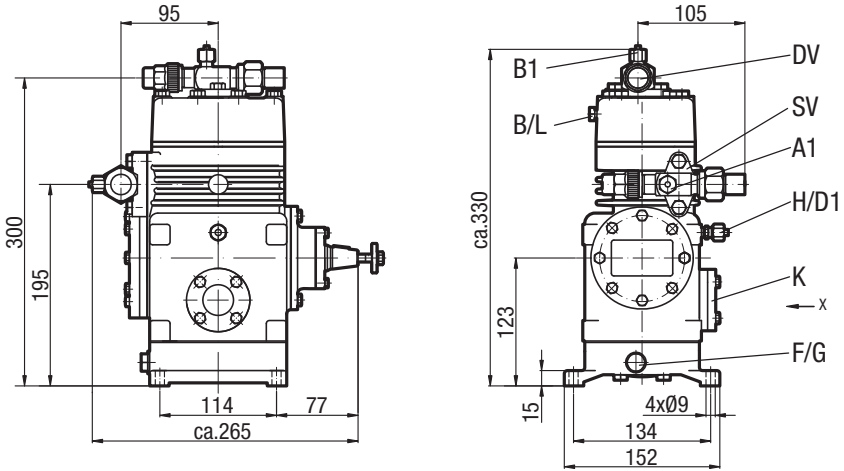

Fig. 36
Dimensions in mm

GB

Shaft end F2 NH₃

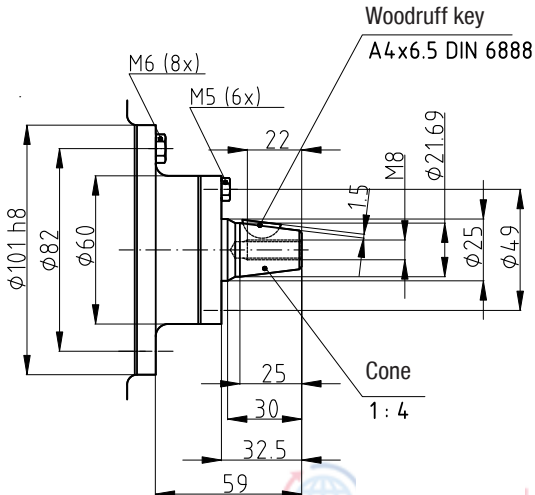

Fig. 37
Dimensions in mm
Dimensions for view X see page 40

09702-09.2013-DGbF

11 | Dimensions and connections F-NH₃

Compressor type F3 NH₃

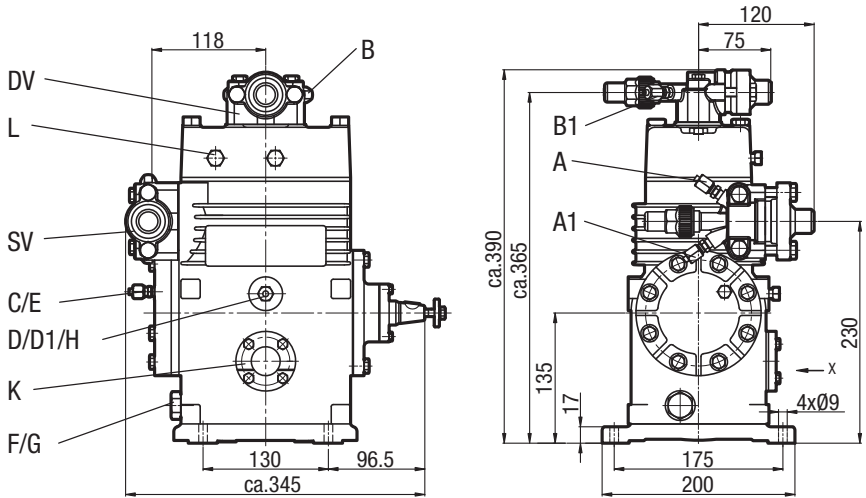

Fig. 38
Dimensions in mm

Shaft end F3 NH₃

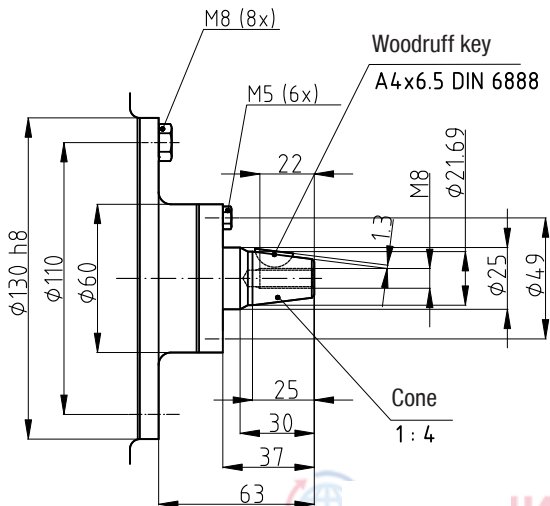

Fig. 39
Dimensions in mm
Dimensions for view X see page 40

GB

11| Dimensions and connections F-NH₃

Compressor type F4 NH₃

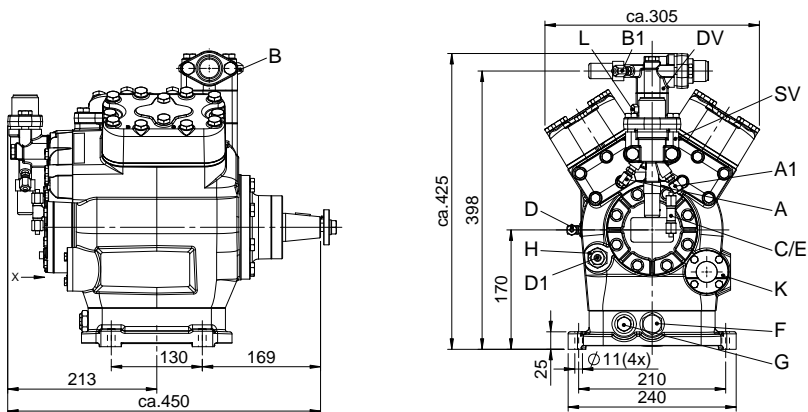

Fig. 40
Dimensions in mm

GB

Shaft end F4 NH₃

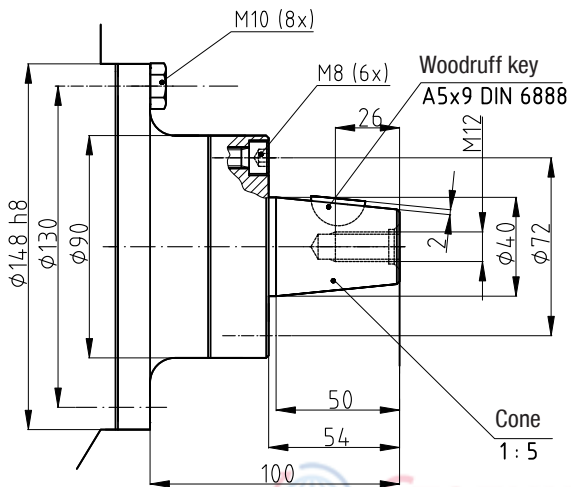
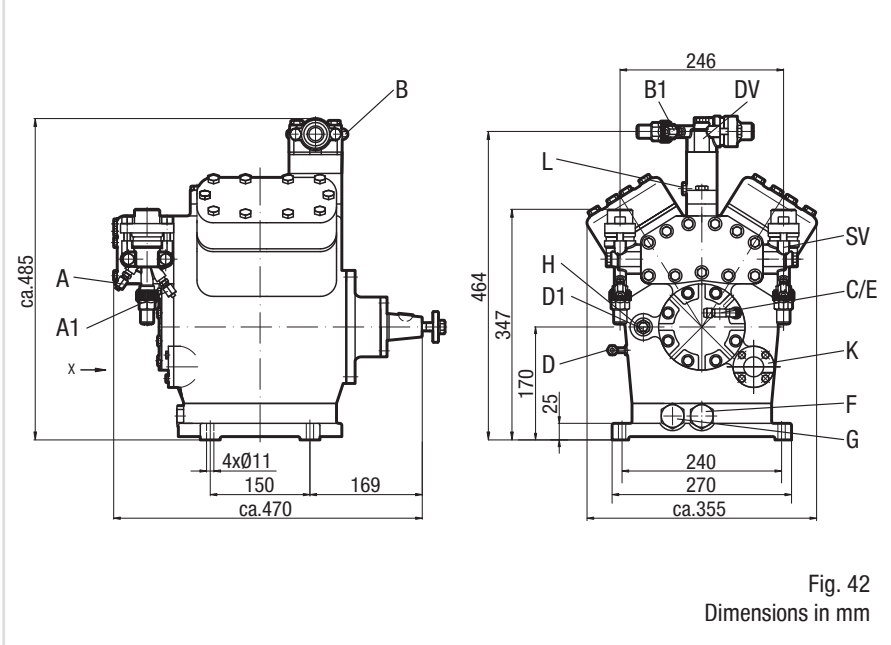

Fig. 41
Dimensions in mm
Dimensions for view X see page 40

11| Dimensions and connections F-NH₃

Compressor type F5 NH₃



Shaft end F5 NH₃

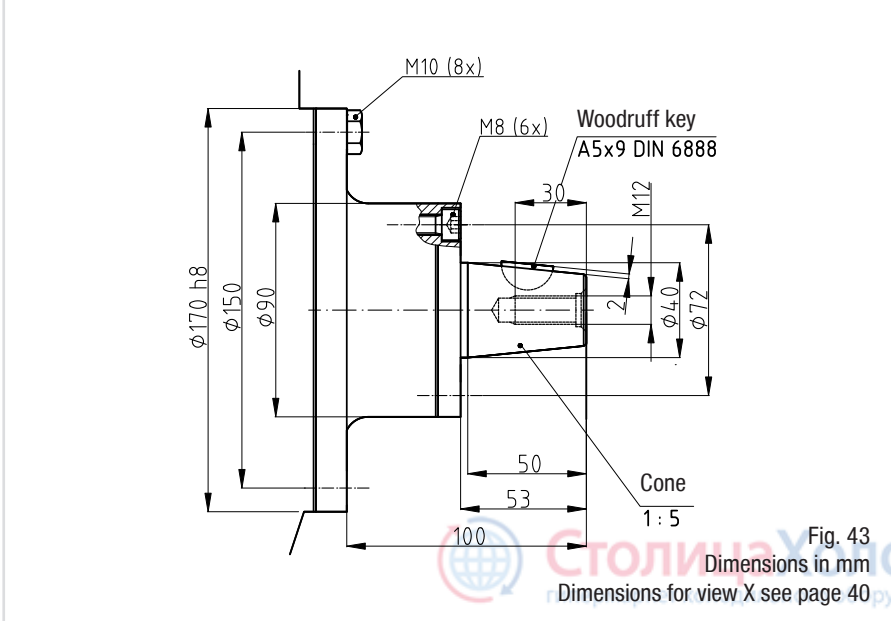

GB

09702-09.2013-DG6F

11 | Dimensions and connections F-NH₃

Compressor type F14 NH₃

F14/1166 NH₃

F14/1366 NH₃

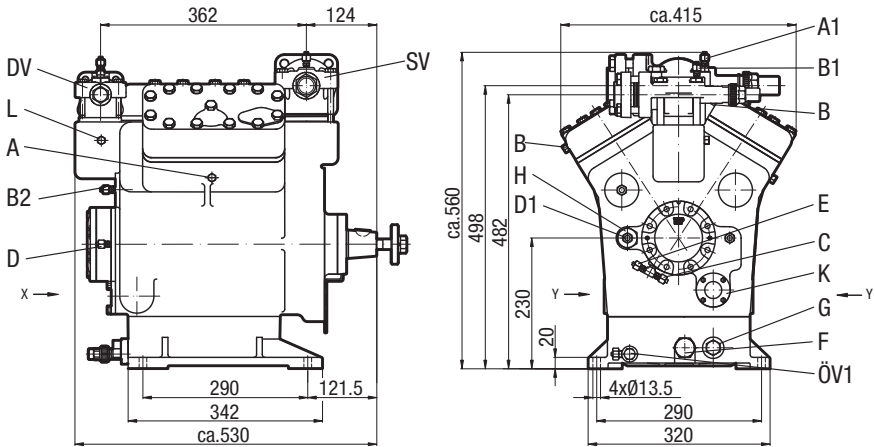

Fig. 44
Dimensions in mm

GB

Shaft end F14 NH₃

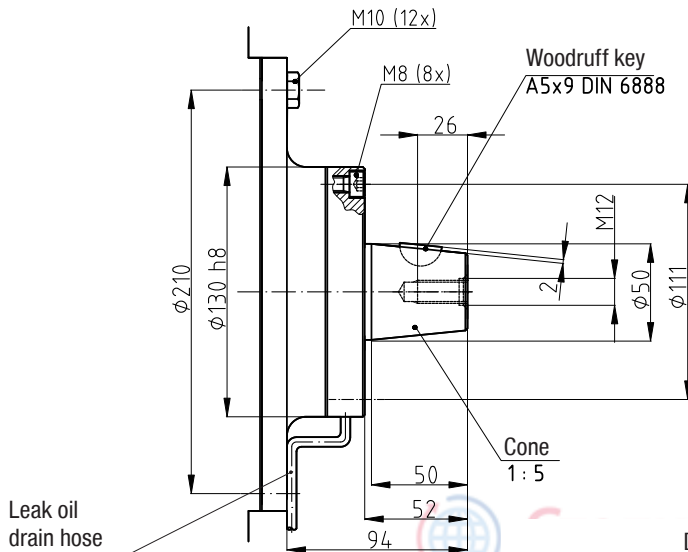

Fig. 45
Dimensions in mm
Dimensions for view X, Y see page 40

09702-09.2013-DGbF

11 | Dimensions and connections F-NH₃

Compressor type F16 NH₃

F16/1751 NH₃

F16/2051 NH₃

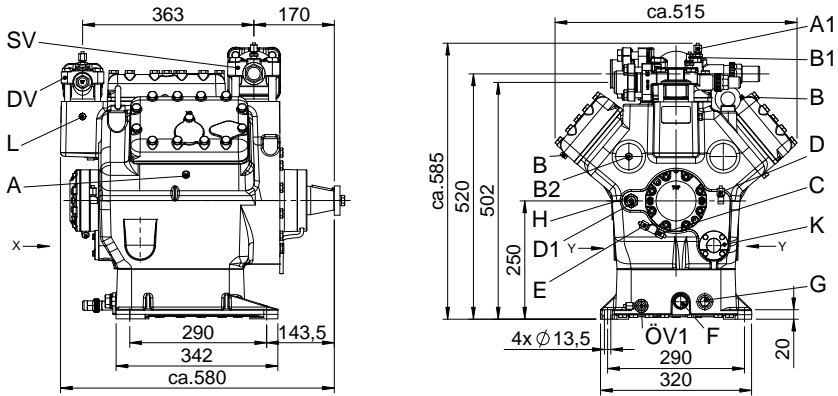

Fig. 46
Dimensions in mm

Shaft end F16 NH₃

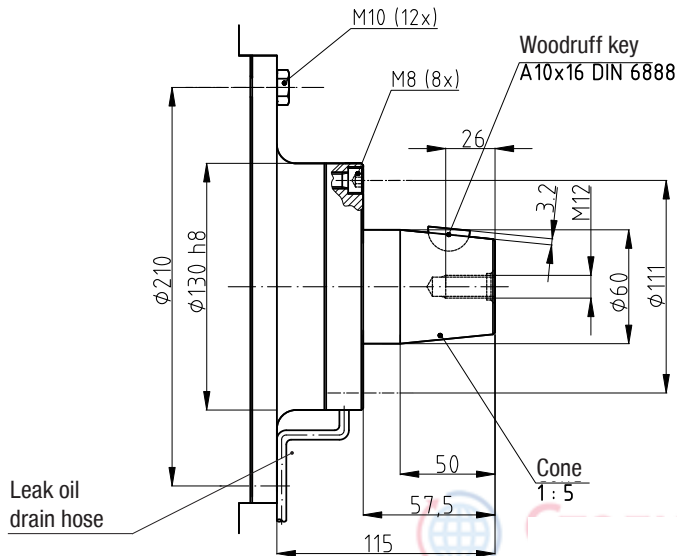

Fig. 47
Dimensions in mm
Dimensions for view X see page 40

GB

11| Dimensions and connections F-NH₃

Connections	F2 NH ₃	F3 NH ₃	F4 NH ₃	F5 NH ₃	F14 NH ₃	F16 NH ₃
SV DV Suction line Discharge line	see technical data, Chapter 8, F-NH ₃					
A Connection suction side, not lockable	-	Ø 6 V ¹⁾	Ø 6 V ¹⁾	Ø 6 V ¹⁾	1/8 " NPTF ¹⁾	1/8 " NPTF ¹⁾
A1 Connection suction side, lockable	Ø 6 V ¹⁾	Ø 6 V ¹⁾	Ø 6 V ¹⁾	Ø 6 V ¹⁾	Ø 6 V ¹⁾	Ø 6 V ¹⁾
B Connection discharge side, not lockable	1/8" NPTF	Ø 6 V ¹⁾	Ø 6 V ¹⁾	Ø 6 V ¹⁾	1/8 " NPTF ¹⁾	1/8 " NPTF ¹⁾
B1 Connection discharge side, lockable	Ø 6 V ¹⁾	Ø 6 V ¹⁾	Ø 6 V ¹⁾	Ø 6 V ¹⁾	Ø 6 V ¹⁾	Ø 6 V ¹⁾
B2 Connection discharge side, not lockable	-	-	-	-	Ø 6 V ¹⁾	Ø 6 V ¹⁾
C Connection oil pressure safety switch OIL	-	Ø 6 V ¹⁾	Ø 6 V ¹⁾	Ø 6 V ¹⁾	Ø 6 V ¹⁾	Ø 6 V ¹⁾
D Connection oil pressure safety switch LP	-	Ø 10 V ¹⁾	Ø 6 V ¹⁾	Ø 6 V ¹⁾	Ø 6 V ¹⁾	Ø 6 V ¹⁾
D1 Connection oil return from oil separator	Ø 10 V ¹⁾	Ø 10 V ¹⁾	Ø 10 V ¹⁾	Ø 10 V ¹⁾	Ø 10 V ¹⁾	Ø 10 V ¹⁾
E Connection oil pressure gauge	-	Ø 6 V ¹⁾	Ø 6 V ¹⁾	Ø 6 V ¹⁾	Ø 6 V ¹⁾	Ø 6 V ¹⁾
F Oil drain plug	R 3/8"	M22 x 1,5	M22 x 1,5	M22 x 1,5	M26 x 1,5	M26 x 1,5
G Oil sump heater plug	R 3/8"	M22 x 1,5	M22 x 1,5	M22 x 1,5	M22 x 1,5	M22 x 1,5
H Oil charge plug	Ø 10 V ¹⁾	Ø 10 V ¹⁾	M22 x 1,5	M22 x 1,5	M22 x 1,5	M22 x 1,5
K Sight glass	4 hole M6	4 hole M6	4 hole M6	4 hole M6	4 hole M6 ²⁾	4 hole M6 ²⁾
L Connection thermal protection thermostat	1/8" NPTF	1/8" NPTF	1/8" NPTF	1/8" NPTF	1/8" NPTF	1/8" NPTF
ÖV Oil service valve	-	-	-	-	Ø 6 V ¹⁾	Ø 6 V ¹⁾

1) Compression joint for steel pipes

2) Second sightglass can be attached, positioning view Y (optional, only as original equipment)

11|Dimensions and connections F-NH₃

11.1 View X, Y

- Oil sight glass
- Connection facility for parallel operation

Position view X:

F2 NH₃, F3 NH₃, F4 NH₃, F5 NH₃,

F14 NH₃, F16 NH₃

4 hole oil sight glass

Position view Y:

F14 NH₃, F16 NH₃

Second oil sight glass can be attached as an option (available as original equipment only)

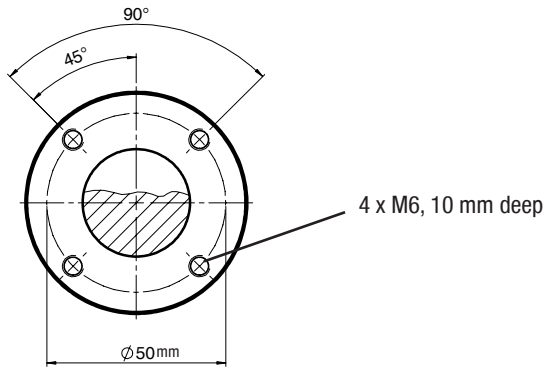

Fig. 48

GB



12| Declaration of installation

DECLARATION OF INSTALLATION

for using the compressors within the European Union
(in accordance with Machinery Directive 2006/42/EC)

The manufacturer: GEA Bock GmbH, Benzstraße 7
D-72636 Frickenhausen, Tel.: 07022/9454-0

hereby declares that the refrigerating compressor **F2, F3, F4, F5, F14, F16 and F2 NH₃, F3 NH₃, F4 NH₃, F5 NH₃, F14 NH₃, F16 NH₃** conforms to the essential requirements of Annex II 1B of the Machinery Directive 2006/42/EC.

Applied harmonised standard:

EN 12693:2008 and the corresponding standards referenced

A partly completed machine may only be put into operation, when it has been established that the machine, into which the partly completed machine is to be installed, conforms to the regulations of the Machinery Directive (2006/42/EC).

The manufacturer undertakes to transmit electronically the special documentation required by individual states for partly completed machinery upon request.

The special technical documentation required for partly completed machinery has been created in accordance with Annex VII Part B.

Person responsible for documentation is:
Wolfgang Sandkötter, Benzstraße 7, 72636 Frickenhausen.

Frickenhausen, 01.11.2011



ppa. Wolfgang Sandkötter,
Chief Development Officer

GB



13| Service

Dear customer,

Bock compressors are top-quality, reliable and service-friendly quality products.

If you have any questions about installation, operation and accessories, please contact our technical service or specialist wholesaler and/or our representative. The Bock service team can be contacted by phone with a **toll-free hotline 00 800 / 800 000 88** or via **e-mail: bock@gea.com**.

Yours faithfully

GEA Bock GmbH
Benzstraße 7
72636 Frickenhausen
Germany

We also provide information on the Internet at **www.bock.de**.

For example, under the "Documentation" link you will find:

- Technical information
- Product information
- Product brochures
- and much more

GB



Столица Холода
гипермаркет холодильного оборудования

09702-09.2013-DGbF

создаем холод

сохраняем тепло

www.stolichaholoda.ru



СтолицаХолода
гипермаркет холодильного оборудования

создаем холод

сохраняем тепло 43

www.stolicaholoda.ru



We live our values.

Excellence • Passion • Integrity • Responsibility • GEA-versity

GEA Group is a global engineering company with multi-billion euro sales and operations in more than 50 countries. Founded in 1881, the company is one of the largest providers of innovative equipment and process technology. GEA Group is listed in the STOXX® Europe 600 index.

GEA Refrigeration Technologies

GEA Bock GmbH

Benzstraße 7, 72636 Frickenhausen, Germany
Telephone: +49 7022 9454-0, Fax: +49 7022 9454-137
bock@gea.com, www.bock.de



СтолицаХолод
гипермаркет холодильного оборудо

создаем холод

сохраняем тепло

www.stolicaholoda.ru